

Ta'limul Fiqh - Grade 6

Title: **Ta'limul Fiqh - Grade 6**

Compiled and Published by:

Jamiatul Ulama (KZN)
Ta'limi Board
4 Third Avenue
P.O. Box 26024
Isipingo Beach
4115
South Africa

Tel: (+27) 31 912 2172
E-mail: info@talimiboardkzn.org
WhatsApp: (+27) 788789980

First Edition: Raae'ul Awwal 1444 / October 2022

ISBN: 978-0-6397-1039-6

Permission is granted for reprinting this booklet without any alterations. A humble appeal is made to the readers to offer suggestions/corrections to improve the quality of this publication. May Allah Ta'ala reward you for this. The authors, editors and typesetters humbly request your duas for them, their parents, families, Asaatizah and Mashaikh.



CONTENTS

Tayammum.....	7
Masah on Khuffain.....	11
Qiblah	16
Qadhaa Salaah	21
Musaafir (traveller).....	24
Sajdatut Tilaawah	28
Sajdatus Sahwu.....	32
Saum (Fasting).....	35
Nafil (Optional) Fast	45
Qadhaa and Kaffarah Fasts	47
Fidyah	50
Taraaweeh.....	52
I'tikaaf.....	55
Laylatul Qadr	59
Sadaqatul Fitr	62
The Day of Eid	66
Qurbaani.....	71





Aqeeqah	83
Zakaat	86
Nisaab	91
Hajj	97
Umrah.....	104





SYLLABUS BREAKDOWN FOR THE YEAR

PART ONE
1ST HALF OF THE YEAR

LESSON: 1 TO 15

PART TWO
2ND HALF OF THE YEAR

LESSON: 16 TO 27



Part One



Lesson One

TAYAMMUM



Definition: To purify oneself using sand when no water is available or water cannot be used.

- Tayammum is a substitute for water when one needs to make wudhu or ghusal.
- The procedure of tayammum for wudhu and ghusal is the same. The only difference is the intention.
- A person can perform any number of salaah he wishes with one tayammum.

A person will be allowed to make Tayammum in the following cases:

1. When water is not available within a radius of 1.7 kilometers.
2. When one has only drinking water available and it is so little that if the water is used for wudhu or ghusal, then there is fear of thirst.

3. When there is fear of an enemy or dangerous animal near the water.
4. When one does not have sufficient money to pay for water which is being sold at a very high price.
5. When one is unable to make wudhu due to illness.

Items on which Tayammum can be made

1. Sand
2. Stone
3. Dust
4. Clay
5. Limestone
6. Walls made of brick, mud or stone, which has not been painted.



Items on which Tayammum cannot be made

1. Metal
2. Glass
3. Wood
4. Food items
5. Anything that can melt or burn to ash

NOTE: Any item with a thick layer of dust on it can be used for tayammum e.g. A wooden desk with a thick layer of dust on it.



Things that break Tayammum

1. Those things that break wudhu will break tayammum.
2. If water becomes available, tayammum will break.
3. If a person made tayammum due to sickness and then got cured, his tayammum will break.

Nabi صَلَّى اللهُ عَلَيْهِ وَسَلَّمَ said, “The (whole) earth has been made a Masjid (a place of salaah) and a means of purification for me (for tayammum), so wherever a person of my Ummah may be at the time for salaah, let him read salaah.”
(Bukhaari # 335)

Questions

1. What is the meaning of Tayammum? _____

2. Mention 5 items with which a person can make Tayammum. _____



3. Mention 3 items with which a person cannot make Tayammum. _____

4. If water is not available within a radius of 1.7 kilometers, will tayammum be permissible? _____

5. Mention 2 occasions when tayammum is permissible. _____

6. If a person made tayammum due to sickness, when will his tayammum break? _____

7. How many Salaah are you allowed to read with one tayammum? _____



Lesson Two

MASAH ON KHUFFAIN

Khuff: A leather sock. (Khuffain: Two leather socks)

Masah on Khuffain: To pass wet hands over one's leather socks whilst making wudhu instead of washing one's feet.

Conditions for making Masah

In order for masah on the khuffain to be correct, the khuffain should be such that:

- Water must not seep through it.
- The sock must be so strong that a person can walk with it for 5 kilometers without it getting torn.
- It covers the whole foot till above the ankle.
- It holds firm to the foot without being tied i.e. it doesn't slip down.

Note: *It is necessary for one to be in the state of wudhu before putting on the khuffain.*



Duration of Masah

1. A person who is at home will be allowed to make masah on the khuffain for 24 hours. After 24 hours, he will have to remove both the khuffs and wash his feet.
2. A Musaaafir (a person who travels for 77 kilometers or more) will be allowed to make masah on the khuffain for 72 hours.

Method of making Masah

1. Wet the fingers of both the hands and wipe them on the top of the khuffain (right hand on right khuff and left hand on left khuff). Starting from the toes, pull the fingers towards the ankles, ensuring that the fingers go up to the ankles.
2. Masah is only done on the upper surface of the khuff and not on the bottom part/sole.
3. Masah should be done once only on each foot.

Important: The top surface equal to at least three fingers space must be covered when making masah.



Actions that break Masah

1. If one or both the khuff is removed, the masah breaks.
2. If the ankle or the area below the ankle gets exposed by opening the zip, the masah will break.
3. When the time of masah expires, the masah breaks, i.e. after 24 hours for a Muqem (a person not on a journey) and 72 hours for a Musaafir.
4. When ghusal becomes fardh, masah breaks.

NOTE: *“Masah breaks” means that the person will have to remove both the khuffs and wash his feet again.*

General Masaail

1. It is not permissible to make masah on cotton socks.
2. A person in need of ghusal cannot make masah on the khuffain. He will have to remove the khuffain and then make ghusal.
3. A person will start calculating the duration for making masah from the time his wudhu breaks and not from the actual time of putting on the khuffain. For example: a person put on his khuffain at 7:00 am but his wudhu broke at 11:00 am. He will calculate the duration of making masah from 11:00 am and not from 7:00 am.



4. When the time for masah expires, it is not necessary to make a new wudhu. One has to only wash his feet.

Questions

1. What is a khuff? _____

2. What should a person do if his khuffain slips off? _____

3. When will the masah on the khuffain break? _____

4. Must masah be made on the top or the bottom section of the khuff? _____

5. Explain in your own words the method of making masah? _____



Activity for students

Bring a pair of khuffain to the classroom and practically demonstrate how to wear it and how to make masah on it.



Lesson Three

QIBLAH

Definition: Qiblah is the direction towards the Ka’bah

The Ka’bah is the house of Allah Ta’ala situated in Makkah Mukarramah. Muslims from every corner of the world face the direction of the Ka’bah when performing Salaah.

Allah Ta’ala says in the Qur-aan, “Wherever you are then turn your faces towards its (Ka’bah’s) direction.”





Why do we face the Ka'bah (Qiblah)

Muslims around the world face towards one direction for Salaah, the direction of the Qiblah. In this way we all face one direction.

How to find the direction of the Qiblah

In South Africa, the direction of the Qiblah is North, North East (NNE).

If you do not know the direction of the Qiblah you may do the following;

1. Ask a trustworthy Muslim to show you the direction of the Qiblah.
2. Ask any person for the direction of North and from there work out the direction of (NNE).
3. Use a compass to find the direction of North, North East (NNE).
4. If you do not have a compass and cannot find anyone to help you, then make Taharri (i.e. use your discretion to work out the Qiblah). The easiest way to make a good estimate of the Qiblah is to find out where the sun rises and where it sets. The sun rises in the east and sets in the west. If you stand with your right shoulder towards the



sunrise, your chest will be facing north. Shift slightly towards your right and that should be the direction of the Qiblah (i.e. North, North East).

Occasions when it is Fardh to face the Qiblah

1. When performing Salaah
2. When making Sajdah-e-Tilaawat

Occasions when it is preferable to face the Qiblah

1. When calling out the Azaan
2. When making wudhu
3. When reciting the Qur-aan Shareef
4. When making Dua
5. When slaughtering an animal
6. When sleeping
7. When sitting in a Deeni gathering

Occasions when we should not face the Qiblah

1. When relieving ourselves
2. When having a bath
3. When one is undressed



Few rules regarding the Qiblah

1. If a person who is in salaah turns his **chest** away from the Qiblah, his salaah will break.
2. If someone is reading salaah facing the wrong direction, you should turn him towards the right direction. In this manner, his salaah will still be valid.
3. A person made Taharri (estimated) and performed Salaah. Later he realised that his direction was wrong. The Salaah that he read will be correct and he doesn't have to repeat it.

Questions

1. What is the meaning of Qiblah? _____

2. Mention how we can find the Qiblah: _____



3. Mention 3 occasions when we must face the Qiblah._____

4. Mention 2 occasions when we must not face the Qiblah.____

5. Will the salaah of a person who turns his chest away from the Qiblah break?_____

6. What should we do if someone is reading salaah in the wrong direction?_____

7. Will the salaah of a person who read salaah in the wrong direction after making Taharri have to be repeated?_____



Lesson Four

QADHAA SALAAH

Definition: Qadhaa means to perform one's salaah after the time has expired.

Rasulullah (sallallahu alayhi wasallam) has said, “The example of the one who has missed one salaah is like a person who has lost all his family and wealth.” (Bukhaari # 3602)

A Muslim must try to always perform salaah on time.

Rules related to Qadhaa Salaah

1. Qadhaa is compulsory for fardh and waajib salaah.
2. There is no Azaan or Iqaamah for qadhaa salaah read alone.
3. Qadha Salaah can be read at any time during the day or night besides at the time of sunrise, sunset and zawaal.
4. It is permissible to perform qadhaa salaah after the fardh of Fajr and Asr.

- 
5. When a person is performing the qadha salaah, he should make the intention as follows; ‘I am performing Fajr or Zuhr, etc. of such and such day.’
 6. The person who doesn’t know how many salaah he has missed should make his intention like this, e.g. I am reading qadhaa for the first Fajr or first Zuhr, etc. that I missed. He should continue in this manner until his heart is at ease that all his qadhaa salaah are now completed.
 7. If a person has so many qadhaa salaah that he does not know the exact number, then he should make an estimate of all the salaah that he has missed (e.g. 1 month, 6 months, 2 years, etc.). He should then draw up a chart and strike off one salaah at a time as he completes his qadhaa.
 8. Women in the state of haiz and nifaas will not have to make qadhaa for the salaah missed.
 9. If a person missed the four rakaat Sunnat-e-Muakkadah before the fardh of Zuhr, he should read it after the two rakaat Sunnat-e-Muakkadah which comes after the fardh of Zuhr.
 10. If a person broke a nafli salaah after starting it, he will have to repeat it.

“Perform your Salaah before your Salaah is Performed”



Questions

1. What does qadhaa mean? _____

2. Mention the Hadith regarding a person who missed one salaah. _____

3. Is there qadhaa for the sunnah and nafl salaah? _____
4. If a person is making qadhaa for an unknown estimated period of time, what intention should he make? _____

5. Does a woman in the state of haiz and nifaas have to make qadhaa? _____
6. Is there Azaan for the qadhaa salaah read alone? _____
7. Is it permissible to read qadhaa salaah after Fajr and Asr? _____

8. Mention the times when qadhaa Salaah cannot be read? _____

Lesson Five

MUSAAFIR (TRAVELLER)

Definition: A person who travels **77 kilometers** or more out of the boundary of his town is regarded as a ***musaafir*** (traveller).

Rules related to a Musaafir

1. It is waajib for a musaafir to make **Qasr** (shorten the Salaah).
 - **Qasr** is to perform two rakaats for Zuhr, Asr and Esha Salaah, instead of four.
 - A Musaafir will read the fardh of the Fajr and Maghrib Salaah as normal.
2. If the musaafir did not make **Qasr** for Zuhr, Asr and Esha, but instead read the full salaah, his salaah will have to be repeated by making **Qasr**.

- 
3. A musaafir can leave out the sunnah and nafl salaah. However, if he has time, it is better that he reads the sunnah and nafl salaah as well.
 4. A musaafir should not leave out the two sunnats of Fajr.
 5. The musaafir has to read the **Witr Salaah**. He cannot leave it out even if he is in a hurry (as Witr Salaah is waajib).
 6. If a musaafir intends staying at a place for less than 15 days, he will perform his salaah by making Qasr.
 7. If a musaafir intends staying at a place for more than 15 days, he will perform his salaah in full without making Qasr.
 8. If the musaafir is the Imaam (for Zuhr, Asr or Esha) and the *muqtadees* (followers) are all residents (not musaafirs), he (the musaafir) will only read two rakaats and make salaam. After he makes salaam, the followers will stand up and complete the remaining two rakaats without reciting Surah Faatihah or a Surah. They will merely stand up for the duration of three ‘subhaanallahs’ in these two rakaats and complete the salaah as normal.

- 
9. If a musaafir reads salaah behind a *muqem* (resident) Imaam, he will read the full salaah. He will not make Qasr.
 10. The musaafir travelling by plane or train should perform his fardh and Witr Salaah standing, facing the Qiblah, according to the location he is in at that time.

Note: *When planning any holiday or outing, we should ensure that we read all our salaah on time. We should not feel shy to read our salaah in public. A Muslim does not have holiday from salaah.*

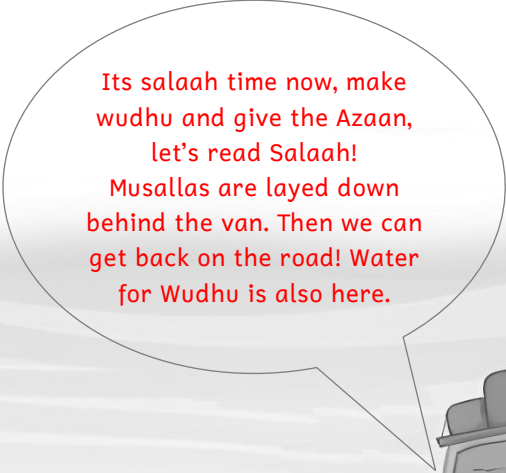

Its salaah time now, make wudhu and give the Azaan, let's read Salaah! Musallas are layed down behind the van. Then we can get back on the road! Water for Wudhu is also here.





Questions

1. When will a person be regarded as a musaafir? _____

2. How many rakaats will a musaafir read for Fajr and Maghrib Salaah? _____

3. Does the musaafir have to read all the sunnah and nafl Salaah? Explain in detail. _____

4. What is Qasr? _____

5. If a musaafir reads salaah behind the local Imaam, will he make Qasr or not? _____
6. If the musaafir is in a hurry, can he leave out the Witr Salaah? _____
7. Should a musaafir travelling by plane or train sit or stand and read his salaah? _____

Lesson Six

SAJDATUT TILAAWAH

Definition: Sajdatut Tilaawah means to make a sajdah after reading or hearing an Aayah (verse) of sajdah from the Qur-aan Shareef.

Status: It is waajib to make Sajdatut Tilaawah.

1. There are 14 Aayaat (verses) of sajdah in the Qur-aan Shareef.
2. The Qur-aan Shareef has a sajdah sign in the margin to indicate the Aayah of sajdah. In addition, the sajdah word is also over lined to make you aware that this is a Sajdah Aayah.

Method of making Sajdatut Tilaawah

Out of Salaah: After reading or hearing an Aayah of sajdah, make intention for Sajdatut Tilaawah. Then, without raising the hands, say Allahu Akbar and go into sajdah. Recite the Tasbeeh in sajdah three times and come up without making



salaam. A person has the option of making the sajdah from the standing posture or from the sitting posture.

In Salaah: As soon as the sajdah Aayah is recited in Salaah, one should immediately make a sajdah and then continue the Salaah as normal.

The conditions that are a pre-requisite for salaah, are also a pre-requisite for Sajdatut Tilaawah i.e. to have wudhu, to face the Qiblah, to be clean, etc.

Few Rules related to Sajdatut Tilaawah

1. Sajdatut Tilaawah is necessary on the one who read the sajdah Aayah as well as the one who heard it.
2. Sajdatut Tilaawah is not necessary on the one who hears an Aayah of sajdah on a cd or recording which is not live.
3. Sajdatut Tilaawah is not compulsory upon a woman who hears the Aayah of sajdah in the state of haiz or Nifaas.
4. It is Makrooh to recite an entire Surah and leave out the Aayah of sajdah.
5. It is forbidden to make Sajdatut Tilaawah during the forbidden times of Salaah like zawaal, sunrise and sunset. It is allowed in the rest of the time.

- 
6. If a person has several Sajdahs to make outside of Salaah, he should complete them as soon as possible. And if he does not have any idea of how many sajdahs were not made, he should go on making the Sajdatut Tilaawah until his heart feels convinced that he has completed the sajdahs that were outstanding.
 7. If a person is memorising a surah and repeats the ayah of sajdah several times whilst sitting in one place, he/she will have to make only one sajdah.

Questions

1. What is the definition of Sajdatut Tilaawah? _____

2. What is the status of Sajdatut Tilaawah? _____
3. What is the method of making Sajdatut Tilaawah out of salaah? _____

4. What is the method of making Sajdatut Tilaawah in salaah? _____

5. There are _____ Aayaat of sajdah in the Qur-aan Shareef.



6. When is it forbidden to make Sajdatut Tilaawah? _____

7. It is _____ to recite an entire surah whilst leaving out the aayah of sajdah.

Activity

Ask your Apa/Moulana to help you find the 14 Aayaat of Sajdah in the Qur-aan Shareef. The first one is provided.

1	Surah A'raaf, aayah: 206
2	
3	
4	
5	
6	
7	
8	
9	
10	
11	
12	
13	
14	



Lesson Seven

SAJDATUS SAHWU

سَجْدَةُ السَّهْوِ

Definition: When a person makes a major mistake in Salaah he will have to make two extra sajdahs at the end of the salaah to cover up for this mistake. This is called Sajdatus Sahwu.

Note: If a person does not make these two sajdahs, then he will have to repeat the entire salaah.

When must one make Sajdatus Sahwu?

Sajdatus Sahwu will be made in the following 5 instances.

When:

- A fardh action is delayed
- A fardh action is repeated
- A waajib action is delayed
- A waajib action is repeated
- A waajib action is left out

Note: *If a person leaves out any fardh action of Salaah, he cannot cover it up by making Sajdatus Sahwu, rather, his Salaah will break and he will have to repeat the Salaah.*

Rules regarding Sajdatus Sahwu

1. If a person deliberately makes any of the above 5 mistakes, he will have to repeat the salaah.
2. If a person misses out a sunnah or nafl act of salaah, he will **NOT** have to make Sajdatus Sahwu (e.g. he did not recite the tasbeeh in ruku or sajdah).
3. A person will only make Sajdatus Sahwu if he is sure he made a mistake. One should not make Sajdatus Sahwu after every Salaah just as a precaution.

Method of making Sajdatus Sahwu

In Qa'dah Akheerah (the last sitting), after reciting tashah-hud, make one salaam to the right and thereafter make two sajdahs, reciting "Subhaana rabbiyal `ala" three times in each sajdah. Thereafter, sit up and complete the salaah as normal by reciting Tashah-hud, Durood-e-Ibraaheem, the dua after Durood-e-Ibraaheem and then make salaam.

Note: If the muqtadee (one reading behind the Imaam) makes a mistake which makes Sajdatus Sahwu necessary on him, he will **NOT** have to make Sajdatus Sahwu.

Questions

1. When will a person have to make Sajdatus Sahwu? _____

2. If the muqtadee makes a mistake, what should he do? _____

3. Explain in your own words how to make Sajdatus Sahwu?

4. What will the position of the salaah be, if a person deliberately makes a mistake which makes Sajdatus Sahwu necessary? _____

Lesson Eight

SAUM (FASTING)

Definition: Fasting means to stay away from eating and drinking from *subh saadiq* (early dawn) until sunset with the intention of fasting.

1. Fasting in the month of Ramadhaan is the 4th pillar of Islam.
2. The fast of Ramadhaan is fardh (compulsory) upon every Muslim, male and female, who is *baaligh* (mature) and sane.

Virtues of Fasting

Allah Ta'ala mentions in the Qur-aan Shareef, “O you who believe, fasting has been made compulsory on you just as it was made compulsory on those before you so that you may attain taqwa (you may become pious).” (Surah Baqarah – Aayah # 183)

Hadhrat Abu Sa'eed Khudri رَضِيَ اللهُ عَنْهُ relates that Rasulullah صَلَّى اللهُ عَلَيْهِ وَسَلَّمَ said, “In every day and night of Ramadhaan Allah



Ta'ala sets free a great number of souls from Jahannam, and for Muslims during every day and night there is a time when their duas are certainly accepted.” (Majmauz Zawaaid # 4 ۷۹۲)

Rasulullah ﷺ said, “Jannah has eight doors. The name of one of them is **Rayyaan**. Only the fasting person will enter through it.” (Bukhaari # 3257)

Allah Ta'ala bestows five special favours to a person who fasts in the month of Ramadhaan:

- The smell from the mouth of a fasting person is sweeter to Allah Ta'ala than the fragrant smell of musk.
- The fish in the sea ask for forgiveness for the one who fasts.
- Allah Ta'ala beautifies and decorates Jannah for the fasting person.
- The evil shayaateen are locked up.
- The fasting person is granted forgiveness on the last night of Ramadhaan.

What intention should one make for fasting?

1. A person should make this intention, ‘**I intend fasting tomorrow**’. Intention from the heart is sufficient. However, it is good to make a verbal intention.

2. The intention for fasting is as follows:

اللَّهُمَّ أَصُومُ غَدًا لَكَ فَاعْفِرْ لِي مَا قَدَّمْتُ وَمَا أَخَّرْتُ

3. Waking up for sehri is an indication that one intends to fast.

Note: *If someone stays away from eating and drinking without any intention, the fast will not be valid.*

Sehri and Iftaar

Sehri is the early morning meal which is eaten before *subh saadiq*.

Iftaar is the meal which is eaten at the time of sunset when one breaks his fast.

Nabi ﷺ has mentioned that, “There is a lot of barakah (blessings) in eating sehri.” (Bukhaari # 1923)

Nabi ﷺ has also mentioned that, “Indeed Allah Ta’ala sends special mercies, and his Angels pray for those who partake of sehri.” (At-Targheeb wat Tarheeb # 1617)



Benefits of waking up for Sehri

1. Partaking of sehri is a sunnah. We will get reward for following a Sunnah.
2. The meal provides strength for the day.
3. It gives one the opportunity to perform Tahajjud Salaah, make Dua and perform Fajr Salaah on time.

Few Rules Regarding Sehri and Iftaar

1. It is mustahab (preferable) to delay the sehri until just before the time expires.
2. It is mustahab (preferable) to make iftaar immediately after sunset.
3. The fast of a person who did not have sehri is valid.
4. Since partaking of sehri is a sunnah and there is a lot of barakah (blessings) in eating sehri, we should therefore try our best to wake up for sehri.
5. At the time of sehri and iftaar, duas are accepted. Thus we should engage in dua at these two times.
6. If a person ate after the sehri time finished, his fast will not be valid.

- 
7. It is mustahab (preferable) to break ones' fast with dates (khajoor) or water. If this is not available, then with whatever is available.
 8. Dua when breaking one's fast:

اللَّهُمَّ لَكَ صُمْتُ وَبِكَ أَمِنْتُ وَعَلَى رِزْقِكَ أَفْطَرْتُ

NOTE: *Minor children should be encouraged to fast in Ramadhaan. However they should not be forced to complete the fast if they cannot manage.*

Fazaail-e-Ramadhaan (Book on the virtues of Ramadhaan)

During the month of Sha'baan we should start reading a few pages of the book 'Fazaail-e-Ramadhaan' daily, at home and in the maktab. It will encourage us to take the maximum benefit of the mubaarak month of Ramadhaan.

Questions

1. What is the definition of fasting? _____

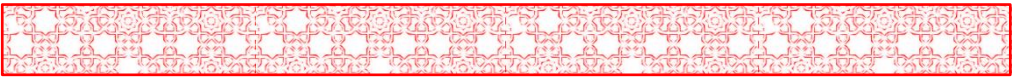

2. On whom is fasting fardh? _____

3. What intention should a person make for fasting? _____

4. Mention one reward for fasting. _____

5. If a person did not make his intention verbally but rather made an intention in his heart, will his fast be valid? _____

6. What is sehri and iftaar? _____

7. It is preferable to break one's fast with _____
8. Mention one reward for having sehri and iftaar. _____

9. Will the fast of a person who did not have sehri be valid? _____



Lesson Nine

Warning for not fasting

Rasulullah ﷺ has said, “Whoever breaks his fast on one day of Ramadhaan without a (valid) excuse or illness, his fasting for his entire life will not compensate it.” (Tirmizi # 723)

People exempted from fasting in Ramadhaan

1. A very sick person who fears losing his life or fears his illness getting worse.
2. A very old person who cannot manage fasting.
3. A person who fears death due to extreme hunger and thirst.
4. A woman in the state of haiz or nifaas.
5. A traveller (musaafir).

Note: Although the above mentioned people will not be fasting in Ramadhaan, they will have to keep these missed fasts later on (after Ramadhaan).



Things that break the fast

1. Eating and drinking intentionally.
2. Vomitting a mouthful intentionally.
3. Putting oil into the ears.
4. To swallow any kind of medicine intentionally.
5. To use a suppository.
6. Water going down the throat when gargling (while being conscious that one is fasting).
7. Smoking.
8. To inhale smoke or steam intentionally or to use an asthma inhaler.

Things that do not break the fast

1. To eat or drink by mistake (i.e. one forgets that he is fasting).
2. Using itr.
3. Water going into the ears.
4. Applying oil on the body or hair.
5. Taking an injection.
6. Applying surma to the eyes.
7. Using a miswaak.

8. Swallowing your own saliva or phlegm.
9. Taking a blood test.

Actions that are Makrooh (disliked) whilst fasting

1. To brush your teeth with toothpaste.
2. To collect saliva in the mouth and then swallow it trying to quench one's thirst.
3. To complain of thirst and hunger.
4. To chew or put something in the mouth, e.g. rubber or plastic.
5. To gargle the mouth unnecessarily
6. To commit any sin

Note: *Although these actions will not break the fast, they will definitely decrease the reward of our fast.*

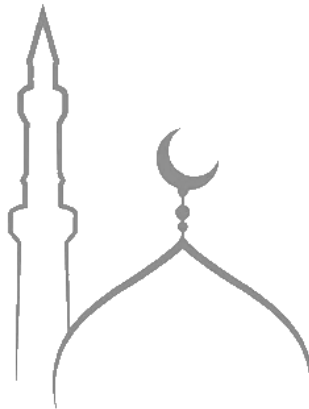



Questions

1. Mention four people who are excused from fasting? _____

2. Will a person's fast break if he uses a miswaak? _____

3. A person went to the doctor and took an injection, will his fast break? _____

4. Mention two actions that are makrooh while fasting. _____

Lesson Ten

NAFL (OPTIONAL) FAST

Apart from Ramadhaan, there are other Nafl (optional) fasts during the year. A person will receive a lot of reward for fasting on these days.

1. Fasting in the month of Muharram especially on the 9th and 10th or the 10th and 11th.
2. Fasting in the month of Sha'baan especially on the 15th.
3. Any six days in Shawwaal.
4. The first 9 days of Zul Hijjah.
5. Every Monday and Thursday.
6. Fasting on the 13th, 14th and 15th of every Islamic month.

Days that are Haraam to Fast on

It is **Haraam** to fast on **FIVE** days in the year. They are:

- Eidul Fitr (1st Shawwaal)
- Eidul Ad-haa (10th Zul-Hijjah)
- Three days after Eidul Ad-haa (11th, 12th, 13th Zul-Hijjah)

Questions

1. Mention the 5 days which are haraam to fast on? _____

2. Mention three Nafil fasts. _____



Lesson Eleven

QADHAA AND KAFFAARAH

FASTS قِضَاءٌ وَكَفَّارَةٌ

Qadhaa: To keep a fast in place of a fast that was missed or broken.

Kaffarah: To keep 60 fasts one after the other (without a break in between) as a penalty for intentionally breaking a fast of Ramadhaan without a valid reason.

Few Rules Regarding Qadhaa

1. If a person breaks any fast, he will have to keep a qadhaa to cover up for it.
2. The person who has many qadhaa fast to keep, does not have to keep them all at one time. However, he/she should not delay in keeping them.
3. A person cannot keep a qadhaa fast in the month of Ramadhaan. These fasts can only be kept before or after Ramadhaan.

- 
4. If a person **forgetfully** (i.e. he forgot that he was fasting) eats or drinks, his fast will **not break** and he will **not** have to keep a qadhaa fast.
 5. The person who **forgetfully** ate or drank but thereafter ate or drank again thinking that his fast had broken, will have to keep a qadhaa fast.
 6. A woman whose fast broke due to haiz or nifaas, will have to keep a qadhaa.
 7. It is not permissible to break a nafl fast without a valid reason. If a person breaks a nafl fast, he will have to keep qadhaa for the broken fast.
 8. If a person vomits a mouthful intentionally, his fast will break and qadhaa will be necessary.

Few Rules Regarding Kaffarah

1. If a person intentionally eats or drinks whilst fasting during Ramadhaan, his fast will break and he will have to keep a qadhaa fast followed by the 60 kaffarah fasts.
2. These 60 Kaffarah fasts will have to be kept one after the other without a break in between.
3. If a person, whilst keeping his kaffarah fasts, misses out one or two in between (even if it is due to sickness), he will have to start the 60 fasts all over again.

- 
4. Taking any kind of medication intentionally without a valid excuse will make qadhaa and kaffaarah necessary.
 5. Before commencing with the kaffaarah fasts one should ensure that neither Ramadhaan nor any of the forbidden days for fasting falls in between e.g. Eid-ul-Adhaa. (if any of these days do fall in between one will have to restart his kaffaarah.)

Questions

1. What is the meaning of qadhaa fast? _____

2. Kaffaarah means to keep _____ fasts _____
_____ without a break in between.
3. A person was keeping his kaffaarah fast. After 51 fasts he got sick and didn't fast for one day. What should he do? ____

4. Will a persons' fast break if he eats or drinks unintentionally? _____
5. By the breaking of which type of fast will Kaffaarah become necessary? _____

Lesson Twelve

FIDYAH

فِدْيَةٌ

Definition: Fidyah is an amount which is given to poor Muslims as a compensation for each missed fast of Ramadhaan.

Fidyah can only be given by a very old person or an extremely sick person who has no hope of recovering from his sickness after Ramadhaan.

Few Rules Related to Fidyah

1. The Fidyah amount is equal to the amount of Sadaqatul Fitr. It can be given in cash (money) or kind (food).
2. Ask some pious Aalim regarding the amount to pay for fidyah.
3. The Fidyah amount has to be given to poor Muslims.
4. It is not permissible to pay the Fidyah for the fasts before the month of Ramadhaan.

- 
5. If after Ramadhaan, the old person gains strength or the sick person recovers, he has to keep qadhaa of the fasts that he missed. He will be rewarded for whatever Fidyah he gave.

Questions

1. What is the definition of Fidyah? _____

2. What should a very old person do if he cannot keep the Ramadhaan fast? _____

3. If a sick person recovers after paying the Fidyah, what should he do? _____

Lesson Thirteen

TARAAWEEH تَرَائِج

Definition: Taraaweesh Salaah is a special salaah performed in the month of Ramadhaan after the Esha Salaah. This salaah consist of 20 rakaats.

Nabi ﷺ mentioned in a Hadith, “He who performs (Taraaweesh) Salaah in Ramadhaan with Imaan and with the hope of earning reward, all his past (minor) sins will be forgiven.” [Bukhaari # 37]

Few Rules related to Taraaweesh Salaah

1. Taraaweesh Salaah is **sunnat-ul-muakkadah** for males and females.
2. Males will perform the Taraaweesh Salaah with jamaat.
3. Females will perform the Taraaweesh Salaah in their homes individually (not in jamaat).
4. The time for the Taraaweesh Salaah is after Esha.
5. The Taraaweesh Salaah consists of **twenty rakaats** in sets of two (i.e. 10 x 2 rakaats).

- 
6. It is **mustahab** to rest for a short while after every four rakaats.
 7. It is **Sunnah** to complete the entire Qur-aan Shareef once in the Taraaweeh Salaah during the month of Ramadhaan.
 8. If there is no Haafiz available, then the person performing the Taraaweeh Salaah can read from any part of the Qur-aan Shareef.
 9. If a person has the strength to stand, it will be **makrooh** for him to sit and read the Taraaweeh Salaah.
 10. The Witr Salaah will be read in jamaat after the Taraaweeh Salaah (for males only).
 11. Taraaweeh Salaah must be performed on every night in Ramadhaan.
 12. The person who came late for Taraaweeh should join the jamaat and should complete the missed rakaats after the Witr Jamaat.
 13. There is no qadhaa for Taraaweeh Salaah.
 14. It is NOT permissible for a Haafiz to take remuneration or gifts for performing the Taraaweeh Salaah.



Questions

1. What is Taraaweeh Salaah? _____

2. How many rakaats are there in the Taraaweeh Salaah? _____

3. Taraaweeh Salaah is _____ on males and females.
4. When is the Witr Salaah performed in Ramadhaan? _____

5. Mention one virtue that has been stated in the Hadith for reading Taraaweeh Salaah? _____

6. If a person has the strength to stand, it will be _____ for him to sit and read the Taraaweeh Salaah.
7. If a person missed few rakaats of Taraaweeh Salaah, when should he complete it? _____

8. Is there qadhaa for Taraaweeh Salaah? _____
9. It is _____ to complete the whole Qur-aan Shareef once in the Taraaweeh Salaah during the month of Ramadhaan.

Lesson Fourteen

I'TIKAAF

إِعْتِكَافٌ

Definition: I'tikaaf means to stay in the Masjid with the intention of I'tikaaf (remaining there for a period of time).

Nabi صَلَّى اللهُ عَلَيْهِ وَسَلَّمَ has mentioned, “The one who sits for ten days I'tikaaf in the month of Ramadhaan, will get the reward of two Hajj and Umrah.” [At-Targheeb wat Tarheeb # ١٦٣٩]

Few Rules regarding I'tikaaf

1. The person sitting for I'tikaaf is called a **Mu'takif**.
2. To sit in I'tikaaf for the last ten days of Ramadhaan in the Masjid is sunnatul mu'akkadah alal kifaayah. This means that if no person sits for I'tikaaf in that Masjid then the whole community will be sinful, and if some people sit then the whole community will be absolved of this duty.
3. Men must sit for I'tikaaf in a Masjid.

- 
4. One cannot sit for Sunnah I'tikaaf out of the month of Ramadhaan. Sunnah I'tikaaf is exclusive to the last ten days of Ramadhaan.
 5. The person sitting for Sunnah I'tikaaf should use his time constructively in the recitation of the Qur-aan, making zikr, making dua, performing nafl salaah, reading authentic Islamic kitaabs, etc.
 6. The Mu'takif is not allowed to leave the Masjid boundary except for the following reasons:
 - To make wudhu
 - To have a compulsory bath
 - To relieve oneself
 - For a genuine necessity. For example a fire broke out in the Masjid or to fetch food, if there is no one to bring it for him.
 7. If a person came out of the Masjid without a valid reason intentionally or unintentionally, his I'tikaaf will break and he will have to keep qadhaa for it. He will keep qadhaa for one day only and not for ten days. The manner of keeping qadhaa is that he will sit in I'tikaaf from sunset to the sunset of the next day with the intention of Qadhaa I'tikaaf. One will also have to fast for that day.



Things permitted during I'tikaaf

- Sleeping
- Eating and drinking
- Changing one's clothes
- Discussing matters of Deen.

I'tikaaf for women

Women may also sit for I'tikaaf in the last 10 days of Ramadhaan. A woman will sit for I'tikaaf in her home in a room which she feels is suitable.

Nafil I'tikaaf

1. Whenever a person enters the Masjid, he can make intention for Nafil I'tikaaf. For as long as he is in the Masjid, he will be rewarded for his intention.
2. Nafil I'tikaaf can be made for any amount of time.
3. Before entering the Masjid for salaah or any Deeni program, a person should make intention for Nafil I'tikaaf



Questions

1. Who is a Mu'takif? _____

2. What is the meaning of sunnatul mu'akkadah alal kifaayah? _____

3. Mention 3 reasons when the Mu'takif can leave the Masjid? _____

4. Where should a woman sit for I'tikaaf? _____

5. What is the status of I'tikaaf in the last ten days of Ramadhaan? _____
6. Mention those things that are permitted to do during I'tikaaf. _____

7. When can a person make Nafil I'tikaaf and for how long? _____

Lesson Fifteen

LAYLATUL QADR نَيْلَةُ الْقَدْرِ

Definition: Laylatul Qadr is a special night in Ramadhaan granted to us as a special gift from Allah Ta'ala. One who makes Ibaadat on this night gets the reward of more than 1000 months of ibaadat.

Regarding Laylatul Qadr, Nabi صَلَّى اللهُ عَلَيْهِ وَسَلَّمَ said, “Verily a month (Ramadhaan) has come on you wherein lies a night (Laylatul Qadr) better than a thousand months. Whoever misses such a night has indeed been deprived of all good.”

[Nasa'ee # 2421]

Nabi صَلَّى اللهُ عَلَيْهِ وَسَلَّمَ has also mentioned, “Whoever makes Ibaadat on Laylatul Qadr with Imaan and being hopeful of Allah Ta'ala's reward, will have his past sins forgiven”.

[Bukhaari # 35]

Nabi صَلَّى اللهُ عَلَيْهِ وَسَلَّمَ has encouraged us to search for Laylatul Qadr on the odd nights of the last ten nights of Ramadhaan i.e. 21st, 23rd, 25th, 27th and 29th night of Ramadhaan.

This night is full of goodness and blessings. We should try our best to search for Laylatul Qadr and spend it in the worship of Allah Ta'ala.

What should be done on this night

- Read extra nafl salaah
- Make lots of Istighfaar (asking Allah Ta'ala for forgiveness), Durood Shareef and Zikr.
- Recite lots of Qur-aan Shareef.
- Make lots of dua

Special dua to read on this night

Nabi صَلَّى اللهُ عَلَيْهِ وَسَلَّمَ has taught us the following dua to read in abundance on this night:

اللَّهُمَّ إِنَّكَ عَفُوفٌ تُحِبُّ الْعَفْوَ فَاعْفُ عَنِّي

O Allah, indeed You are most forgiving. You love to forgive, so please do forgive me.



Questions

1. What is Laylatul Qadr? _____

2. Mention one Hadith regarding Laylatul Qadr. _____

3. Ibaadat on Laylatul Qadr is equal to Ibaadat for _____
_____ months.

4. When should we search for Laylatul Qadr? _____

5. Mention 2 things that we should do on Laylatul Qadr? _____

SADAQATUL FITR صَدَقَةُ الْفِطْرِ

Definition: Sadaqatul Fitr is the charity given to the poor Muslims so that they can also enjoy something to eat for Eid.

Hadhrat Ibnu Abbaas رَضِيَ اللهُ عَنْهُ has mentioned that, “Nabi صَلَّى اللهُ عَلَيْهِ وَسَلَّمَ made Sadaqatul Fitr compulsory to cleanse our fast from all mistakes and immorality and also as a means of providing food for the poor.” [Ibnu Maajah # 1827]

Sadaqatul Fitr is compulsory upon all those on whom zakaat is compulsory. However, the money does not have to be in his possession for one lunar year (as is the case of Zakaat).

A person should discharge Sadaqatul Fitr for himself and on behalf of his wife and minor children.

Few Rules regarding Sadaqatul Fitr

1. Sadaqatul Fitr becomes compulsory on the morning of Eidul Fitr when Fajr time sets in. If a person passes away before Fajr time sets in, Sadaqatul Fitr will not be compulsory on him.

- 
2. Sadaqatul Fitr becomes compulsory whether a person fasted in Ramadhaan or not.
 3. It is mustahab to discharge the Sadaqatul Fitr before the Eid Salaah.
 4. One may also discharge the Sadaqatul Fitr in the month of Ramadhaan before the day of Eid.
 5. Before Ramadhaan comes to an end, we should ask an Aalim regarding the amount that needs to be given as Sadaqatul Fitr.
 6. Sadaqatul Fitr can be given in cash or goods.
 7. If a person did not give Sadaqatul Fitr for previous years, he should pay the equivalent of the current year's Sadaqatul Fitr amount for the previous years missed.

Note: *Sadaqatul Fitr can only be given to poor Muslims who are eligible to receive zakaat.*



Questions

1. What is Sadaqatul Fitr? _____

2. On whom is Sadaqatul Fitr compulsory? _____

3. When does Sadaqatul Fitr become compulsory (time)? _____

4. When is it mustahab to discharge Sadaqatul Fitr? _____

5. If a person passes away before Fajr time sets in, will Sadaqatul Fitr become necessary on him? _____
6. Who can Sadaqatul Fitr be given to? _____

7. What should a person do if he did not give Sadaqatul Fitr for the previous year? _____



Part Two

Lesson Sixteen

THE DAY OF EID

(Eidul Fitr and Eidul Adhaa)

Definition: The days of Eid are days of celebration for Muslims around the world. Rasulallah ﷺ has said that every nation has days of Eid and these are our days of Eid.

Eidul Fitr is on the 1st of Shawwaal. It marks the end of the month of Ramadhaan.

Eidul Adhaa is on the 10th, 11th and 12th of Zul-Hijjah. It honours the sacrifice of Ibraaheem alayhis salaam of his son Ismaa'eel عَلَيْهِ السَّلَام.

Rasulallah ﷺ has said, “Whoever keeps the nights of the two Eids alive (i.e. he stays awake and makes Ibaadat), his heart will not die on the day when all hearts will be dead.” (Ibnu Maajah # 1782)

We should try and spend a portion of the nights of Eid in the worship of Allah Ta'ala and reap this great reward.

Etiquettes to observe on the day of Eid

- Wake up early.
- Have a bath according to the sunnah.
- Use the miswaak.
- Wear ones best Islamic clothing (not necessarily new).
- Apply itr.
- Go walking for the Eid Salaah.
- Go to the Eidgah (place of eid-salaah) taking one route and return via another route.
- Eat something sweet before going for the Eidul Fitr Salaah.
- Discharge one's Sadaqatul Fitr before going for the Eidul Fitr Salaah.
- To say the takbeer when going for the Eid Salaah; loudly for Eid-ul-Adhaa and softly for Eid-ul-Fitr. The takbeer is:

اللَّهُ أَكْبَرُ اللَّهُ أَكْبَرُ لَا إِلَهَ إِلَّا اللَّهُ وَاللَّهُ أَكْبَرُ اللَّهُ
أَكْبَرُ وَلِلَّهِ الْحَمْدُ



Note: *On the day of Eidul Adha it is advisable that one should not eat anything before the Eid Salaah. Instead, the first thing that one eats should be the meat of the sacrificed animal.*

Rules concerning the Eid Salaah

1. The time for Eid Salaah begins a little while after sunrise and ends before Zawwaal. It is best to perform it as early as possible.
2. Eid Salaah is compulsory on those upon whom Jumuah Salaah is compulsory. Eid Salaah is not compulsory on women.
3. The Eid Salaah consists of two rakaats with six extra takbeers.
4. Eid Salaah is generally performed on the outskirts of the town or in an open field.
5. There is no Azaan and Iqaamah for the Eid Salaah.
6. It is forbidden to perform any nafl salaah at the Eidgaah, neither before the Eid Salaah nor after.

The Khutbah

After the salaah, the Imaam will deliver two Khutbahs. Everyone should sit silently and listen to the Khutbah. It is Sunnah Mu'akkadah to stay and listen to the khutbah.

Unlike Jumu'ah, the Eid Salaah is performed before the two Khutbahs.

Note: During the khutbah, it is *waajib* for one to remain silent and listen attentively to the khutbah.

Important:

Remember that on the day of Eid, we should dress as Muslims. We should not imitate the non-Muslims in their clothing or ways.





Questions

1. On what dates do Eidul Fitr and Eidul Adhaa fall on? _____

2. Mention 5 etiquettes to be observed on the Day of Eid? ____

3. On whom is the Eid Salaah waajib? _____

4. Where is the Eid Salaah generally performed? _____

5. Eid Salaah consists of _____ rakaats with _____
extra takbeers.
6. Will Azaan and Iqaamah be given for the Eid Salaah? _____

7. Do women perform Eid Salaah? _____

Lesson Seventeen

QURBAANI

Definition: Qurbaani means to sacrifice animals on the days of Qurbaani in remembrance of the sacrifice of Hadhrat Ibraaheem alayhis salaam and his son Hadhrat Ismaaeel alayhis salaam.

- The time of Qurbaani starts on the 10th of Zul Hijjah after the Eid Salaah and ends on the 12th of Zul Hijjah at sunset.
- There is more reward to do the Qurbaani on the 10th, then the 11th and then the 12th of Zul Hijjah.
- Those living in the city can only start cutting their Qurbaani animals after the Eid Salaah is over.
- Those living in far-off villages and farms where there is no Eid Salaah, can make Qurbaani once Subh Saadiq (Fajr time) sets in.

Virtues of making Qurbaani

Allah Ta'ala says in the Qur-aan, "It is neither its meat nor its blood that reaches Allah; rather, it is your piety that reaches Him." [Surah Hajj – Aayah 37]

Nabi صَلَّى اللهُ عَلَيْهِ وَسَلَّمَ mentioned in a Hadith: “There is nothing dearer to Allah Ta’ala during the days of Qurbaani than the sacrificing of animals. The sacrificed animal will come on the day of Qiyaamah with its horns, hair and hooves (to be weighed). The sacrifice is accepted by Allah Ta’ala before the blood reaches the ground. Therefore sacrifice with an open heart.” [Tirmizi # 1493]

Once, the Sahaabah رَضِيَ اللهُ عَنْهُمْ asked Nabi صَلَّى اللهُ عَلَيْهِ وَسَلَّمَ, “O Nabi of Allah صَلَّى اللهُ عَلَيْهِ وَسَلَّمَ! What is Qurbaani?” He replied, “It is the sunnah of your father Ibraaheem عَلَيْهِ السَّلَامُ.” They then asked, “What benefit will we get from it?” He replied, “A reward for every hair of the sacrificed animal.” They then asked, “And what about an animal with wool?” Nabi صَلَّى اللهُ عَلَيْهِ وَسَلَّمَ replied, “A reward for every fibre of wool.” [Ibnu Maajah # 3127]

Warning for not carrying out Qurbaani

Nabi صَلَّى اللهُ عَلَيْهِ وَسَلَّمَ said, “The person who has the means for making Qurbaani but does not do so, should not even come near our Musalla (place where Eid Salaah is performed).” [Ibnu Maajah # 3123]

On whom is Qurbaani Waajib?

1. Qurbaani is waajib on all Muslims, males and females who are sane, mature and possess the minimum nisaab (Zakaat amount) on the days of Qurbaani.
2. Qurbaani is necessary on a person for himself only. However, he should make sure that his family members also make Qurbaani if it is waajib on them.
3. Qurbaani is not waajib on the poor (those who do not possess nisaab), travellers and minors.
4. The person who did not do Qurbaani of previous years (despite it being waajib on him) should give the current value of a Qurbaani animal to the poor with the intention of the qadhaa Qurbaani for each year's missed Qurbaani.
5. It is preferable for a person who is performing Qurbaani that he does not clip his nails or remove his hair from the beginning of Zul Hijjah until the Qurbaani is done.





Questions

1. What is the meaning of Qurbaani? _____

2. When does the time of Qurbaani commence? _____

3. Mention one reward for making Qurbaani? _____

4. What warning did Nabi ﷺ give to those who neglect to make Qurbaani despite having the wealth? _____

5. On whom is Qurbaani waajib? _____

Lesson Eighteen

Animals which can be slaughtered for Qurbaani

1. The following animals, whether male or female, can be slaughtered for Qurbaani: goats, sheep, cattle (cows, bulls and buffalo) and camels.
2. Goats and sheep have to be at least one year old. However, a very healthy sheep which is 6 months or older but looks like a one year old animal, may also be slaughtered.
3. Cattle must be at least two years old.
4. Camels must be at least five years old.
5. Sheep and goats count as only one share, i.e. one sheep or goat will only suffice as Qurbaani for one person.
6. Cattle and camels are divided into seven shares, i.e. seven people can share in one cow or one camel. If more than seven people share in a cow or camel, the Qurbaani of all the shareholders will be invalid.

Note: When looking to purchase an animal, we should choose a good quality animal. We shouldn't be miserly and look for a cheap animal. Qurbaani is a great act of worship. Therefore we should present the best we can to Allah Ta'ala. The healthier (i.e. the more valuable) the animal, the more the reward we will receive in the Hereafter.

Note: Remember not to show off with one's animals as all our rewards will be lost.

Few Rules regarding the Qurbaani Animal

1. If the Qurbaani animal was under age, the Qurbaani will not be valid and it will have to be repeated.
2. The animal chosen for Qurbaani should be healthy and free from any defects.
3. If the animal has the following defects, it will not be permissible for Qurbaani:
 - The horn is broken off from the root. However, if the horns are cut off, it will be permissible.
 - Those animals that are totally blind or have lost more than half of their eyesight.
 - An animal that has no teeth at all. However, if it is able to graze, it will suffice for Qurbaani.
 - Animals born without ears. If it has very small ears, it can be slaughtered.
 - Very thin and weak animals.
 - If the entire tail is cut. Even though it was cut due to medical reasons.

Note: *If less than half of the tail, ear or eyesight is cut or lost, the Qurbaani will be valid, and if half or more than half is cut or lost, the Qurbaani will not be valid.*

4. If an animal sustains an injury whilst being slaughtered (e.g. the leg breaks), the Qurbaani of such an animal will be valid.

Rules pertaining to Zabah (slaughtering)

1. It is preferable for a person to slaughter his own animal if he knows how to slaughter correctly.
2. A woman can also slaughter her own animal. However, ensure that the laws of purdah are adhered to.
3. It is preferable for a person to slaughter during the day. However, if the Qurbaani is carried out at night in a place which is well lit and there is no fear of one making a mistake while slaughtering, the Qurbaani will be permissible.
4. One should not be cruel to the animal or ill-treat it in any way. Rather, one should treat the animal with kindness and compassion. Make sure that the animal is not put through any difficulty unnecessarily.
5. When laying the animal down, one should place the animal on its left side facing towards the Qiblah. Say

“Bismillahi Allahu Akbar” and swiftly pass the knife over its neck, cutting all four veins.

Recite the following Dua when slaughtering the animal:

بِسْمِ اللّٰهِ اَللّٰهُ اَكْبَرُ

6. If the Tasmiyah (Bismillahi Allahu Akbar) was left out intentionally, the animal will be haraam to consume.
7. Ensure that the knife is very sharp before slaughtering. It is makrooh to use a blunt knife.
8. When slaughtering the animal, make sure that four veins are properly cut: the throat, two jugular veins and the wind pipe.
9. If only three veins were cut, it will still be permissible to consume that animal. However, if only one or two veins were cut, this animal will be haraam to consume.
10. One animal should not be slaughtered in front of another.
11. After slaughtering the animal, allow it to cool down first before skinning it (at least 5 minutes).

Lesson Nineteen

The Meat and Skin of the Qurbaani Animal

1. Eating the meat of the Qurbaani animal is also sunnah. If possible, this should be the first thing we eat on the day of Qurbaani.
2. It is preferable that the meat be divided into three parts; one part for oneself, one part for ones relatives and one part for the poor and needy. If a person wants, he may keep the entire animal for himself.
3. The Qurbaani meat can be given to Muslims, non-Muslims, the poor and the rich.
4. No part of the animal can be given as payment to workers. The workers should be paid separately for their work.
5. If more than one person shared in an animal and they request for the meat, then it is necessary to distribute the meat equally (by weight) amongst them. If any shareholder receives more, it will be regarded as ribaa (interest) which is totally haraam.
6. The skin of the Qurbaani animal can be kept for personal use or could be given to anyone else for their personal use.

- 
7. If the skin is sold, the amount received cannot be used by oneself. It will be necessary to give that amount in charity.
 8. It is not permissible to give the value of a Qurbaani animal to a poor person instead of doing the Qurbaani ourselves.

Takbeer-e-Tashreeq

Definition: Takbeer-e-Tashreeq is a special Takbeer which is recited on the days of Hajj.

The Takbeer is:

اللَّهُ أَكْبَرُ اللَّهُ أَكْبَرُ لَا إِلَهَ إِلَّا اللَّهُ وَاللَّهُ أَكْبَرُ اللَّهُ أَكْبَرُ وَلِلَّهِ
الْحَمْدُ

1. The Takbeer-e-Tashreeq will be recited after every Fardh Salaah from the Fajr of the 9th of Zul-Hijjah to the Asr of the 13th of Zul-Hijjah (23 salaahs in total).
2. The Takbeer-e-Tashreeq is waajib upon all mature males and females. Men will recite it audibly and women will recite it softly.
3. The Takbeer is also waajib on a Musaafir and those performing salaah individually.



4. The Takbeer will not be said after the Witr Salaah.
5. A person who joins the Jamaat Salaah late in the Masjid will say the Takbeer after he has performed his missed rakaats. He will also say it audibly.
6. The Takbeer-e-Tashreeq should also be recited after the Eid Salaah.

Questions

1. List the animals which can be slaughtered for Qurbaani? __

2. How old should a cow be if you want to slaughter it for Qurbaani? _____

3. What kind of animal should be chosen for Qurbaani? _____

4. Which four veins should be cut properly when making zabah? _____





5. If an animal was born without ears, can it be slaughtered for Qurbaani?_____

6. What is Takbeer-e-Tashreeq?_____

7. For how many salaahs will the Takbeer-eTashreeq be recited?_____

8. Write the words of the Takbeer-e-Tashreeq!_____

9. If more than seven people share in a cow, will the Qurbaani be valid?_____

10. Can you pay the workers with any part of the Qurbaani animal?_____

11. What is the preferable way of dividing the Qurbaani meat?_____



Lesson Twenty

AQEEQAH

Definition: Aqeeqah means to sacrifice an animal on the 7th day after a child is born.

Hadhrat Salmaan (radhiyallahu anhu) said, “I heard Rasulullah ﷺ say, ‘Aqeeqah is to be offered for a (newly born) boy, so slaughter (an animal) for him, and remove all dirt from him.’” [Bukhaari, 5154]

Few rules regarding Aqeeqah

1. By sacrificing an animal for Aqeeqah, the newly born child will be protected from all calamities by the grace of Allah Ta’ala.
2. To do Aqeeqah is sunnah.
3. Aqeeqah is done on the 7th day after the child is born.
4. The child will be given a name on the 7th day and his/her hair will be shaved off. The equivalent weight of the hair in silver must be given in Sadaqah (charity).

- 
5. Aqeeqah for a boy is 2 goats or 2 sheep or 2 shares in cattle. If a person can only afford one animal or one share, then this will suffice as well. There is also no harm or sin if Aqeeqah is not performed at all.
 6. Aqeeqah for a girl is one goat, one sheep or one share in cattle.
 7. The Aqeeqah meat can be distributed raw or cooked. A person may eat of it and also give his relatives or friends to eat of it. It can be given to the poor and the rich.
 8. The same conditions that apply to the Qurbaani animal apply to the Aqeeqah animal i.e. age being appropriate, being free from defects, etc.
 9. If a person's Aqeeqah was not done when he was born, it can be done later on in his/her life.



Questions

1. What is the definition of Aqeeqah? _____

2. Is it compulsory to do Aqeeqah? _____

3. What should be done on the 7th day after the child is born? _____

4. How many goats, sheep or shares in cattle will suffice for a boy? _____
5. How many goats, sheep or shares in cattle will suffice for a girl? _____
6. What should be done with the Aqeeqah meat? _____

7. Can a person who did not do Aqeeqah, do it later? _____

Lesson Twenty One

ZAKAAT

Definition: Zakaat means to give charity to the poor Muslims once a year.

Nabi ﷺ has said, “Protect your wealth by discharging Zakaat...” (At-Targheeb wat Tarheeb # 1112)

Nabi ﷺ said, “The one who discharges his Zakaat, his wealth is cleansed from impurity.” (Al Mu’jamul Aosat lit Tabraani # 1579)

1. Zakaat is one of the five pillars of Islam.
2. Zakaat is Fardh once a year.
3. If a person denies zakaat being Fardh, he loses his Imaan.
4. Zakaat is an act of Ibaadat (worship). It is not a tax.

The rewards for paying Zakaat

- One who pays zakaat earns the pleasure of Allah Ta’ala.

- 
- Allah Ta'ala increases the wealth of the person who pays zakaat.
 - Allah Ta'ala protects the wealth of the person who pays zakaat.

The punishment for not giving Zakaat

- Allah Ta'ala mentions in the Qur-aan, “Those who hoard gold and silver and do not spend it in the path of Allah, inform them of a painful punishment. On the day of Qiyaamah it will be heated in the fire of Jahannam. Then they will be branded (burnt) with it on their foreheads, their sides and backs. (It will be said to them). This is your treasure which you hoarded for yourselves, so taste the treasure that you had been hoarding.”
- It is stated in a Hadith, “The person whom Allah Ta'ala has bestowed with wealth and does not pay its zakaat, on the day of Qiyaamah his wealth will be turned into a poisonous bald snake which will wrap around his neck and bite his jaws saying, ‘I am your wealth. I am your treasure.’” (Bukhaari # 1403)
- Rasulullah ﷺ said, “The nation that does not pay zakaat, Allah Ta'ala will hold back the rains from them (they will suffer drought).” (Ibnu Maajah # 4019)



Some benefits of giving Zakaat

1. One's wealth increases.
2. It brings about barakat (blessings) in ones' wealth and protects it from all types of losses (which could have been a result of theft or calamities).
3. It serves as a shield from the fire of Jahannam.
4. It attracts the pleasure of Allah Ta'ala.
5. It saves one from the love and greed for wealth.
6. The poor are taken care of.

Nabi ﷺ has mentioned, “If a man pays the zakaat due on him, it causes its evil effects to vanish.” [Mustadrak Haakim # ١٤٣٦]

On whom is Zakaat compulsory?

Zakaat is fardh on all adult Muslim men and women who are sane (not mad) and who possess a certain amount of wealth (nisaab) for one lunar year.

Types of wealth on which Zakaat is Fardh

1. Gold and silver (be it in any form, e.g. jewellery, coins).
2. Cash (whether it is with you, in the bank or owed to you).
3. Goods that are bought with the intention of resale.

- 
4. Livestock (Animals that a person owns, e.g. goats, sheep, cattle, etc.)

Types of wealth on which Zakaat is not Fardh

- There is no zakaat on precious stones like diamonds, pearls, etc. if it is not for the purpose of re-selling.
- There is no zakaat on all metals besides gold and silver unless it is for trade.
- There is no zakaat on household items such as furniture, utensils, tools, etc.
- There is no zakaat on one's personal items like one's clothes, shoes, books, cars, etc.

Questions

1. What is zakaat? _____

2. What is the status of zakaat? _____
3. On whom is zakaat compulsory? _____

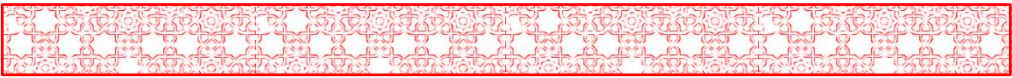

4. Mention one punishment for not giving zakaat. _____

5. Mention the types of wealth on which zakaat is payable?_

6. Mention one warning for those who neglect to pay their zakaat? _____

7. A person bought lots of diamonds and pearls to sell. Does he have to give zakaat on that? _____

8. Does a person have to pay zakaat on his household items? _____

9. Mention four benefits of paying zakaat? _____



Lesson Twenty Two

NISAAB

Definition: Nisaab is that amount of wealth which makes it compulsory for a person to pay zakaat.

1. The nisaab amount in cash changes all the time (depending on the current price of gold and silver). The easiest way to find out how much is the nisaab amount is to ask some Aalim you know.
2. If a persons' wealth equals to or is more than the nisaab and it is in his possession for **one lunar year** (Islamic year), then he should give **2,5%** of it as zakaat (i.e. $1/40^{\text{th}}$).
3. Zakaat will be fardh on the person who has the nisaab at the beginning of the year and at the end of the year, even though during the course of the year his wealth went less than the nisaab amount.
4. If a person has wealth which is less than the nisaab amount, zakaat will not be compulsory on him.



General rules regarding Zakaat

1. Zakaat should be given immediately when it becomes due.
2. Stipulate a date for calculating your zakaat. For example: Fix the 1st of Ramadhaan as your date for discharging zakaat and every year discharge your zakaat on the 1st of Ramadhaan.
3. **Niyah** (intention) is very important when giving zakaat. A person should have this intention that, “I am giving this wealth as zakaat.” If a person gives some wealth without the intention of zakaat, the zakaat will not be fulfilled.
4. Zakaat can be paid in cash or in the form of goods or food.
5. If a person has the nisaab amount but also has debts which are more than the wealth in his possession, or after deducting the debts, he will have less than the nisaab, zakaat will not be compulsory on him.
6. When discharging zakaat, the person you are giving the zakaat to must be made the **owner** of that wealth. That is, when giving the person zakaat, he cannot be forced or told to use the money in a certain way.
7. It is better that the person distributes his zakaat himself (i.e. he personally gives it to the poor). However, it is

permissible for him to ask someone reliable to distribute it for him.

8. When discharging Zakaat, it is not necessary to inform the receiver that it is Zakaat.



Lesson Twenty Three

Who can / cannot accept Zakaat?

1. Zakaat must be given to the poor. A poor person is one who does not own the nisaab amount.
2. Zakaat can only be given to Muslims. Non-Muslims cannot be given zakaat. Optional charity can be given to Muslims and non-Muslims.
3. Zakaat can be given to a person in debt (whose debt is more than the money that he owns).
4. Zakaat cannot be given for building Masjids, madrasahs, wells, hospitals, etc. Zakaat has to be given to a person, not a building.
5. A person cannot give zakaat to his parents, grandparents, children, grandchildren and spouse.
6. Zakaat can be given to one's brother, sister, uncle, aunty, nephew, niece and cousins.
7. Zakaat cannot be given to Sayyids (i.e. the family members of Nabi Muhammad ﷺ - those whose lineage goes up to Nabi ﷺ).
8. When giving zakaat, give preference to ones' poor relatives first. A person will receive more reward for this.

- 
9. Ensure that the person you are giving the zakaat to is worthy of accepting zakaat. If he is not entitled to accept zakaat, then your zakaat will not be discharged.

Questions

1. What is the meaning of nisaab? _____

2. What is the most important rule when giving zakaat? _____

3. Can zakaat be given to non-Muslims? _____
4. Zakaat can be paid in cash or _____.
5. When giving out our zakaat, who will be given first preference? _____
6. If a person gives his zakaat to someone who is not entitled to receive it, will his zakaat be fulfilled? _____
7. Who is a Sayyid? _____



8. A person gave away some wealth without the intention of zakaat, will his zakaat be fulfilled? _____
9. Can a person give his zakaat to construct a Masjid or a hospital? _____
10. Can you give zakaat to your father? _____
11. Is it necessary for a person to distribute his zakaat himself to the poor or can he ask someone else to distribute it on his behalf? _____



Lesson Twenty Four

HAJJ

Definition: Hajj means to visit the house of Allah Ta'ala in Makkah Mukarramah (during the days of Hajj) and perform some special acts of Ibaadat.

- Hajj is the fifth pillar of Islam.
- Performing of Hajj is the command of Allah Ta'ala.
- The days of Hajj are 8th, 9th, 10th, 11th and 12th or 13th Zul Hijjah.
- Hajj is compulsory on all Muslims who are sane (not mad), physically fit (not blind, crippled, etc.) and have enough wealth to perform Haj as well as leave enough money at home for his family and dependants.
- If any of the above conditions are not found, Hajj will not be compulsory.

Virtues for performing Hajj

- Rasulullah ﷺ has said, “The one who performs hajj for the sake of pleasing Allah Ta'ala and therein utters no word of evil, nor commits any evil deed, he shall return from it free

from sin as the day on which his mother gave birth to.”

[Bukhaari # 1021]

- Rasulullāh ﷺ also said, “Surely there shall be no reward for an accepted hajj except Jannah.” [Bukhaari # 1773]

During the 5 days of Hajj, the Hujjaaj do certain special ibaadats at different places. They go to Makkah, Mina, Arafaat and Muzdalifah and perform the rituals of Hajj.

The highlight of Hajj is Arafaat. If a person doesn't go to Arafaat, his Hajj will not be valid.

Warnings for not performing Hajj

Rasulullāh ﷺ gave a severe warning for not performing Hajj despite it being fardh on a person, “The person who has food, drink and the means of transport to undertake Hajj and still does not go, Allah Ta'ala has no concern if he dies as a Jew or a Christian.” (Tirmizi # 812)

It is reported that Hadhrat Abdullah bin Umar radiyallahu anhu used to say, "Whosoever has health and (sufficient) wealth to bring him for Hajj and still does not go for Hajj and dies without performing it, then on his forehead the word 'KAAFIR' shall be written on the day of Qiyaamah." (Fazaail-e-Hajj pg.32)



Questions

1. What is the definition of Hajj?_____

2. Mention the days of Hajj._____

3. On whom is Hajj fardh?_____

4. What is the highlight of Haj?_____

5. Mention one warning for not performing haj._____

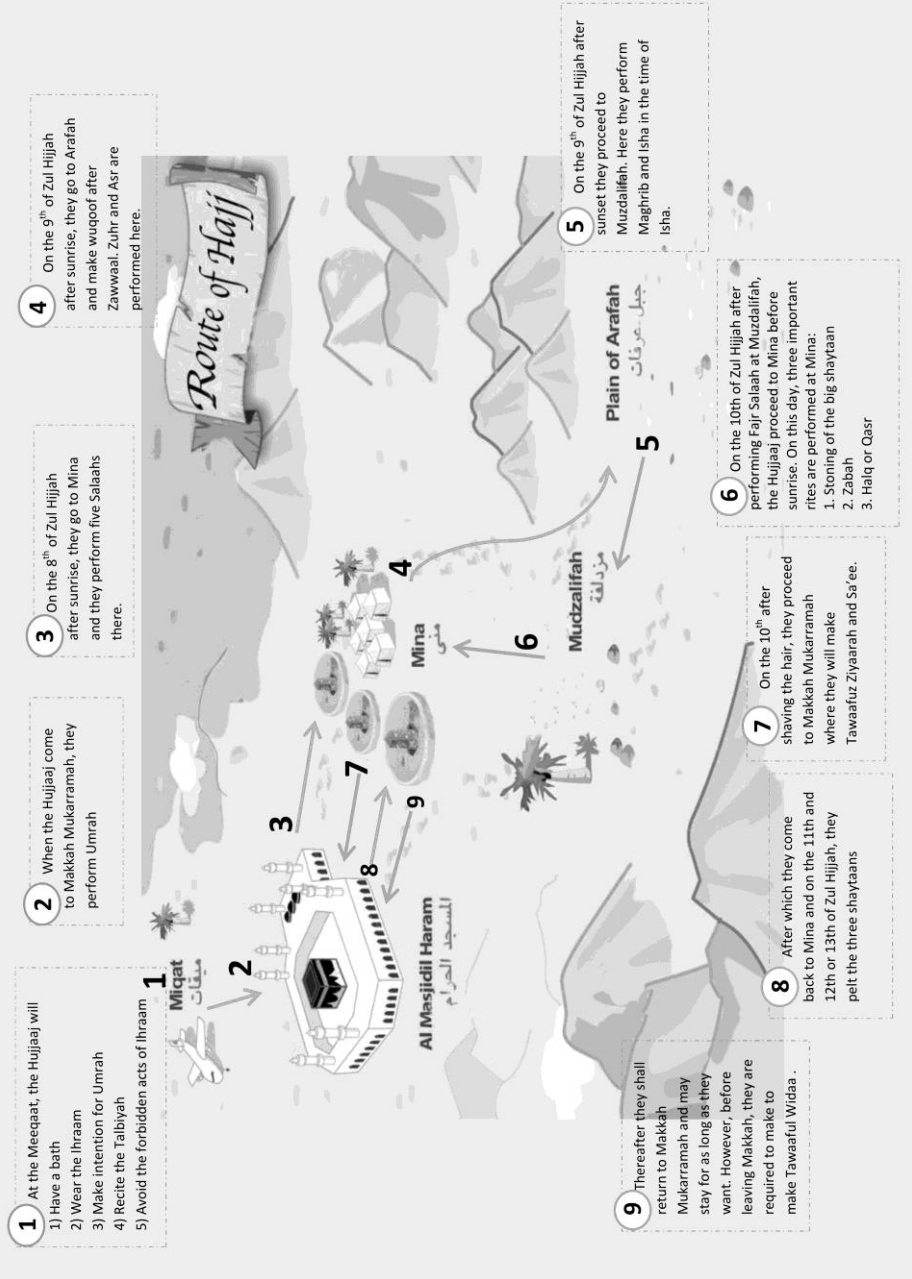



Lesson Twenty Five

Few rules pertaining to Hajj

1. Hajj is fardh only once in a lifetime.
2. If a person performs Hajj before becoming Baaligh (mature), it will not be regarded as his Fardh Hajj but as a Nafil Hajj. When he comes of age, he will have to perform his Fardh Hajj again.
3. Once Hajj becomes fardh on a person, it is necessary for him to go that very year. It is not permissible for him to delay without a valid reason.
4. If a woman wants to go for Hajj, it is necessary for her to be accompanied by her husband or some other mahram (a person to whom a woman cannot get married, e.g. her father, grandfather, son, brother, uncle or nephew). She cannot go without a mahram. If she cannot find a suitable mahram throughout her life, she will not be sinful. However, she should make a bequest that Hajj be performed on her behalf.
5. There are many rules and regulations of Hajj. One will fully understand these rules when one goes personally for Hajj. Before one intends going for Hajj, one should

speak to an Aalim and ask him to explain all the rules to you.

Madinah Munawwarah

A person should also visit the grave of our Nabi Muhammad صَلَّى اللَّهُ عَلَيْهِ وَسَلَّمَ in Madinah Munawwarah, either before Hajj/Umrah or after Hajj/Umrah.

Nabi صَلَّى اللَّهُ عَلَيْهِ وَسَلَّمَ said, “The person who visits me after my demise will receive the same blessings as the person who visited me during my lifetime.” (Al Mujamul Aosat # 287)

Another Hadith says, “The person who goes for Hajj and does not visit me has shown great disrespect to me.” (Fazaail-e-Hajj pg. 157)

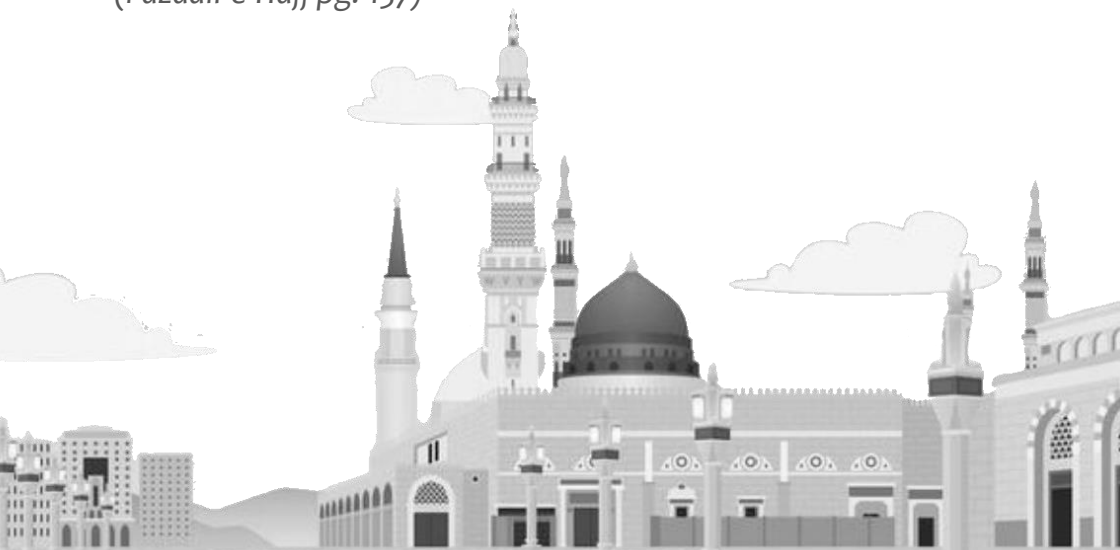



Questions

1. Mention one virtue of performing Hajj. _____

2. How many times in a persons life is Hajj Fardh? _____
3. Who is a Mahram? _____

4. What did Nabi ﷺ say regarding the person who visits his grave? _____

5. If a person performed Hajj when he was a child, is it considered as his fardh Hajj? _____

Lesson Twenty Six

UMRAH

Definition: Umrah means to go to the house of Allah Ta'ala in Makkah Mukarramah and perform some special acts of Ibaadah.

Nabi ﷺ said, “Verily the best of deeds is a righteous and accepted Hajj or a righteous and accepted Umrah.” [At-Targheeb wat Tarheeb # 1687]

Nabi ﷺ has also mentioned that, “One Umrah wipes out the sins committed since the last Umrah.” [Bukhaari # ۱۷۷۳]

- The person performing Umrah is called a Mu'tamir.
- It is sunnat-e-mu'akkadah to perform Umrah once in a person's life.
- Umrah can be performed throughout the year except on the days of Hajj.



The best Umrah is that Umrah which is performed in Ramadhaan. Rasulallah صَلَّى اللهُ عَلَيْهِ وَسَلَّمَ said, “An Umrah performed in Ramadhaan is like performing Hajj with me (in reward).”
[Bukhaari # 1863]

There are many rules and regulations of Umrah which cannot be understood and remembered without really going for Umrah. Before one intends going for Umrah, one should speak to an Aalim and ask him to explain all the rules to him.

Important: The reward for a good deed performed in Makkah Mukarramah is multiplied 100 000 times and in Madinah Munawwarah 50 000 times. Similarly, the severity of sins committed there, are also multiplied. Therefore, we should try our best to do as much good deeds as we can and save ourselves from all sins in those blessed places.

Rules of Umrah in brief

1. Put on the Ihraam before entering the Meeqaat (boundary).
2. Perform two rakaats of sunnah salaah for Ihraam.
3. Say the Niyyah and Talbiyah.

- 
4. Proceed to Makkah Mukarramah, en-route recite the Talbiyah constantly.
 5. Perform Tawaaf. (7 rounds around the Kabah)
 6. Perform two rakaats Waajib Salaah (after the Tawaaf) behind the Maqaam-e-Ibraaheem.
 7. Proceed to the Multazam and Zam Zam well.
 8. Perform Sa'ee between Safaa and Marwah.
 9. Shave or trim the hair of the head.

Questions

1. What is the status of Umrah in Shariah? _____

2. Which is the best time to perform Umrah? _____

3. When can Umrah not be performed? _____

4. What is the reward for doing a good deed in Makkah Mukarramah and Madinah Munawwarah? _____

1. Meeqaat: When a person who is intending to perform Umrah reaches the Miqaat (Boundary of Haram), he will put on his Ihraam, read two rakaat of Salaah and make his Niyaaah.

7. Shave / Trim the Hair: Thereafter, the men can go to the barber and shave their head, and the ladies can go to their rooms and trim their hair. Now you done and out of Ihraam.

6. Safaa Marwah Sa'ee: After Zam Zam, go to Mount Safaa [D] and start with the Sa'ee. You will walk from Safaa to Marwah [E] and that is 1, then back to Safaa and that is 2. You will complete 7 rounds and end up at Marwa.

2. Haram & Kabah: He will then proceed to the Masjidul Haraam where the Kabah is and perform Tawaaf (go 7 times around the Kaba anticlockwise, starting inline with the Black stone [A]). Males should make Idhtibaa (exposing the right shoulder), and in the first 3 rounds (make Ramal (walking briskly with the shoulders raised)).

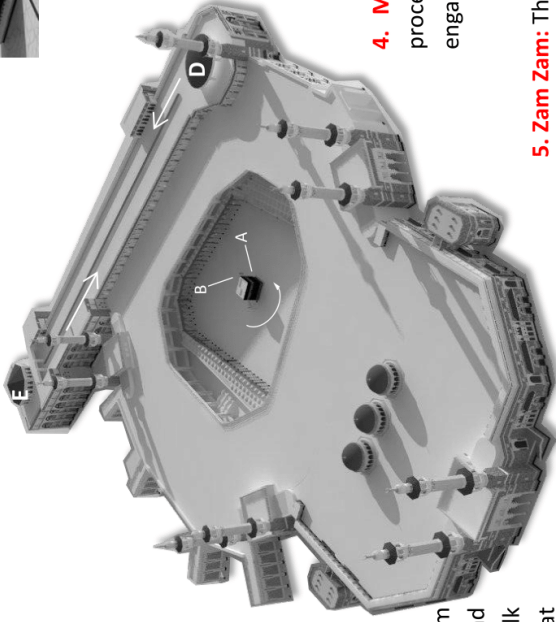
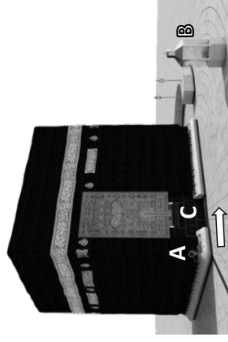

3. Maqaamu Ibraheem [B]: After the Tawaaf he should perform 2 Rakaats wajib salaah anywhere behind the Maqaamu Ibraheem.

4. Multazam: [C] Thereafter, proceed to the multazam and engage in abundant Dua.

5. Zam Zam: Then proceed to the Zam Zam well (or containers) and drink as much Zam Zam as you can and make dua here too.

The Manner of Performing

UMRAH

Lesson Twenty Seven

Points of Interest

Ka'bah: The first house that was built for the worship of Allah

Maqaam-e-Ibraaheem: The Maqaam-e-Ibraaheem refers to the stone on which Ibraaheem alayhis salaam stood on while he was building the Ka'bah

Zam Zam: Zam Zam is the blessed water that sprang miraculously thousands of years ago from the place where Ismaa-eel alayhis salaam was kicking his feet, when he was left with his mother Hajar radiyallahu anha in the desert, thirsty and crying. Duas are accepted when drinking Zam Zam water.

Hajar-e-Aswad: The Hajar-e-Aswad is a black stone that was brought from Jannah and presented to Ibraaheem alayhis salaam to be placed on the corner of the Ka'bah.

Multazam: The area between the door of the Kaba and the Hajre Aswad.

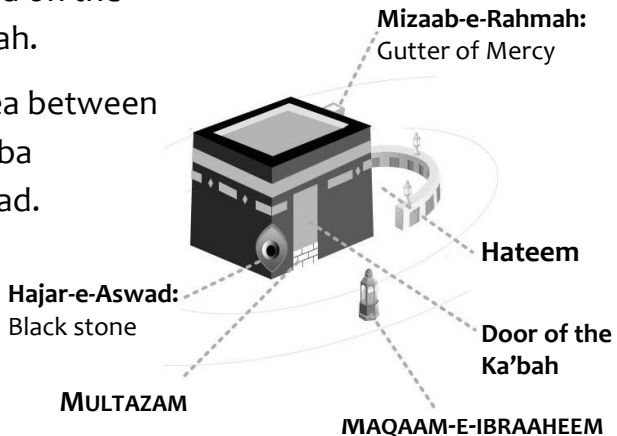



Questions

1. Define the following words:

Maqaam-e-Ibraaheem: _____

Zam Zam: _____

Hajar-e-Aswad: _____

Multazam: _____
